

FORK CLAMP & GAUGE FT-4

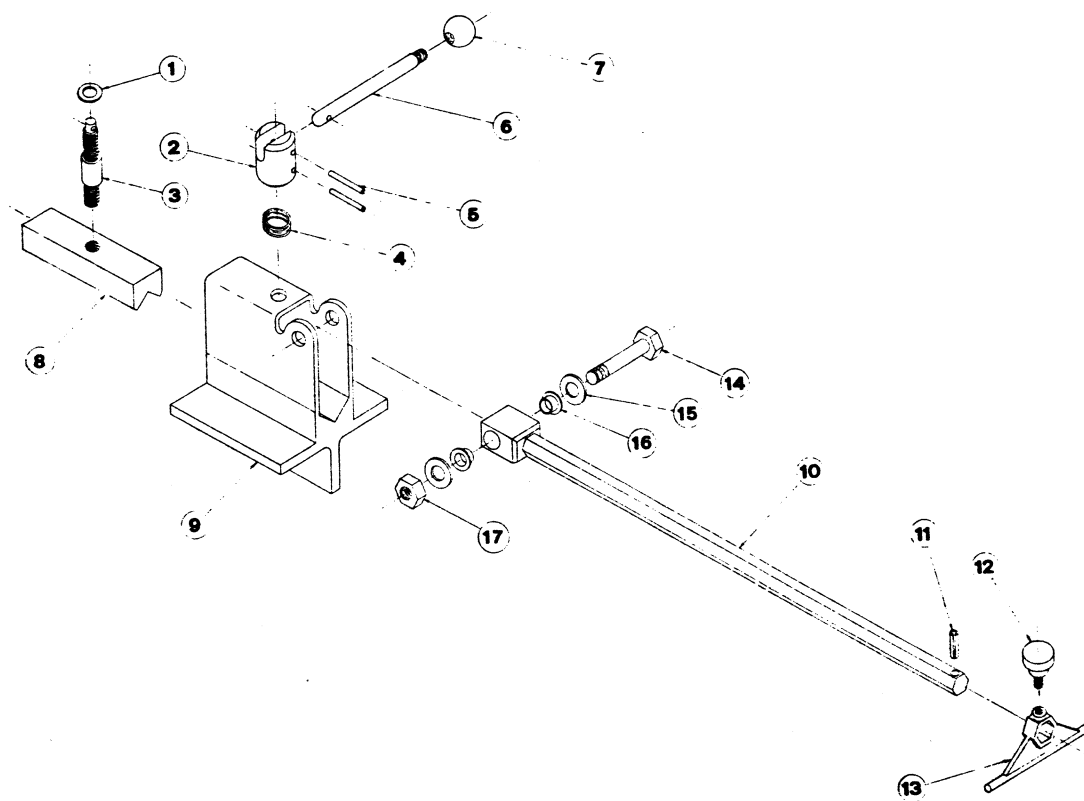

<u>Art Ref. No.</u>	<u>Part No.</u>	<u>Description</u>
(1)	163	Nylon Washer
(2)	167	Knob
(3)	156	Threaded Shaft
(4)	164	Spring
(5)	109S	Split Pin 5/32 x 1 1/4
(6)	111S	Handle
(7)	110S	Ball Knob
(8)	154	Moveable "V" Block
(9)	159	Clamp Body
(10)	161	Gauge Shaft
(11)	165	Split Pin 1/4 x 3/4
(12)	166	Sliding Gauge Knob
(13)	160	Sliding Gauge
(14)	157	Bolt
(15)	205S	Washer 1/2 SAE
(16)	235-2	Nylon Bushing
(17)	233-2	Nut 1/2 - 20